

EXHIBIT B



Detailed Fencing Specifications

The following are required materials and installation procedures for fencing in Century Farm:

MATERIALS

WOOD:

4" x 4", 4" x 6", or 6" x 6" appearance grade WRC posts, beveled at top

2" x 6" - #2 or better DOUGLAS FIR rails (3 each section)

6" wide by 6' tall PICKETS - #2 or better, no-hole, 7/8" thick, inland red cedar - kiln dried

6" wide by 8' long TRIM - #2 or better, no-hole inland red cedar - kiln dried

Exterior galvanized, ring shank nails - both 2" and 3"

3" exterior coated screws

Concrete pre-mixed with water

Welded steel gate frame

Tension cable

Large black gate latch

OPEN METAL:

2" x 2" minimum posts, with caps

Pre-fabricated or custom welded panels at 5' tall consisting of:

3 - 1" horizontal square tube rails, with rails at top and bottom, and 3rd rail at 6" below top rail
5/8" square tube vertical pickets spaced at 4-9/16" on center, welded to all 3 rails

(Panels and posts must be either powder coated or painted electrostatically in a semi-gloss black, high quality product. All welded joints must be ground smooth, and touched up with either electrostatic paint, or a cold galvanizing compound along with a primer and minimum 2 coats of high quality enamel or urethane.)

Concrete pre-mixed with water

INSTALLATION

WOOD FENCE:

POSTS:

- Fence posts are to be appearance grade, non-surfaced (rough), cedar.
- 4" x 4" posts may be used on property line fences, only when hidden within the confines of a back yard.
- All street facing posts, or posts up against common areas must be 4" x 6", or 6" x 6" at a corner exposed on 2 sides.
- All cedar posts must be beveled with a ¾" – 1" bevel on top.
- Posts must be set at least 18" deep in holes that are a minimum of 26" deep, to allow for concrete below post and on all sides of posts, at a minimum of 80 pounds per post. Gate hinge posts are to be 4" x 6" x 9', to allow for deeper installation at 36", and require at least 120 pounds of concrete.
- Concrete must be mixed before added to hole, and may not be "dry set" or mixed inside the hole. Dry concrete or gravel may be used at very bottom of hole for leveling purposes.

RAILS:

- Each fence section must have 3 horizontal rails, using 2" x 6", graded #2 or better Douglas Fir.
- Rails must be attached permanently with 2 screws on each end for a total of 4 screws per rail. Screws are to be exterior galvanized or coated, and at least 3" in length.
- Rails must be installed level across posts, and sections may only step if step is a minimum of 5.5" (NO SLOPING SECTIONS). Bottom rail is not required to be level, and may slope with the contour of soil grade, but must not make ground contact.
- When rail ends on an end or corner post, rail must have a ½" - 1" bevel at the end.

PICKETS:

- Pickets must be 6" wide - #2 or better, kiln dried inland red cedar, 7/8" thick
- Pickets are to be gapped at 4" then overlapped with another layer of pickets thus creating no gaps.
- Pickets should be attached with 2" hot dipped, galvanized, ring shank nails. At least 12 nails must be used per linear foot for pickets.

TRIM:

- Trim must be 6" wide - #2 or better, kiln dried inland red cedar
- Trim must be installed with 3" long, ring shank, hot dipped, galvanized nails, minimum 10 per piece

GATES:

- Gates must be constructed on hinge posts described above, with 5/8" j-lag style hinges, attached to a 1-3/8" steel gate frame. Strong strap hinges may be used in cases when gate must swing outward.
- All gates over 36" must include a diagonal 2" x 6" brace AND a tension cable with turnbuckle.
- A large decorative latch that opens from front or back of gate must be used. Striker for latch is to be bolted through horizontal rail that is attached to steel gate frame with carriage bolts, not fastened with lag bolts.

STAIN:

- ALL cedar must be stained on BOTH sides (special attention to top of fence) with **Woodscapes Flat, Solid stain**, color code **Flagstone Gray #815-T54 (SW3023)** at a rate of 1 gallon for 32 linear feet (1 side).

OPEN METAL:

Open Metal shall be used for all fences along common areas and streets.

POSTS:

- Posts must be at least 16-gauge, 2" x 2" with standard pyramid cap.
- Posts should be set at minimum 18" in ground, in holes at least 26" deep, and are to be pushed into wet concrete or "hot set" so that concrete is inside and around the post.
- Posts are to be installed in a minimum of 80 pounds concrete. Gate hinge posts should have minimum 120 pounds of concrete.

PANELS:

- Panels are to consist of 3 horizontal rails made of 1" steel square tube, with the middle rail set at 6" below the top rail. Vertical pickets must be 5/8" steel square tube, welded to horizontal rails at both ends and 6" down from top.
- Panels are to be attached to posts by welding, or by 1" brackets, inserted inside rails only, and fastened to posts with minimum 1" - #14 hex screws.

GATES:

- Gates are to be constructed of matching materials to wrought iron panels, and hung from standard black open metal iron hinges, either welded or bracketed. Latch should be at least standard open metal iron style gravity latch.

-END-

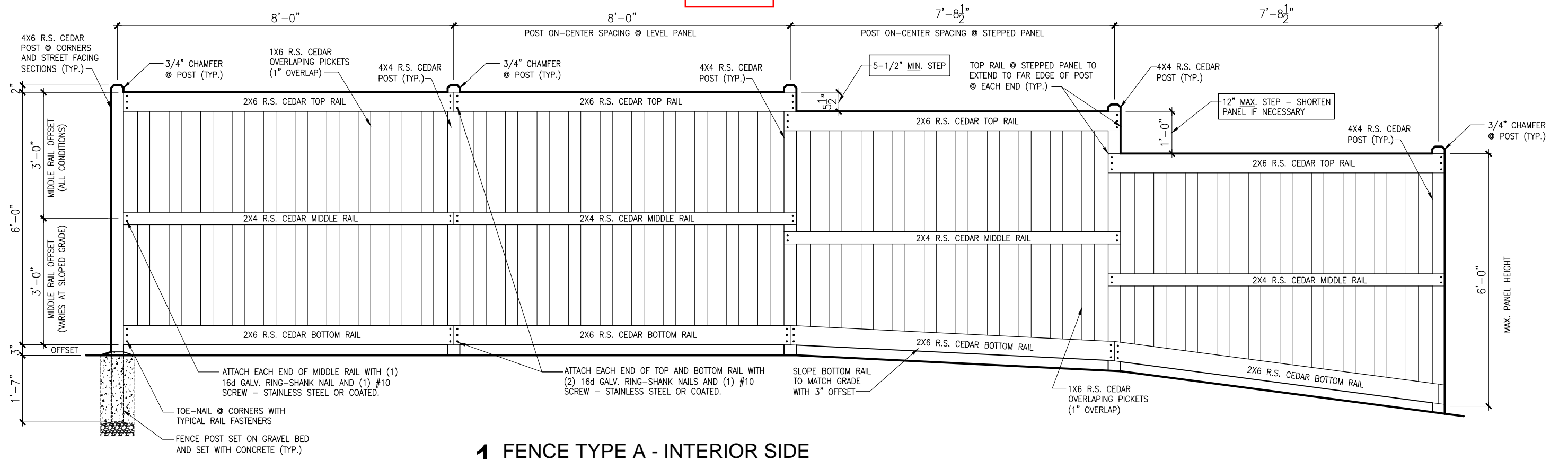

1 FENCE TYPE A - INTERIOR SIDE
SCALE: 1/2"=1'-0"

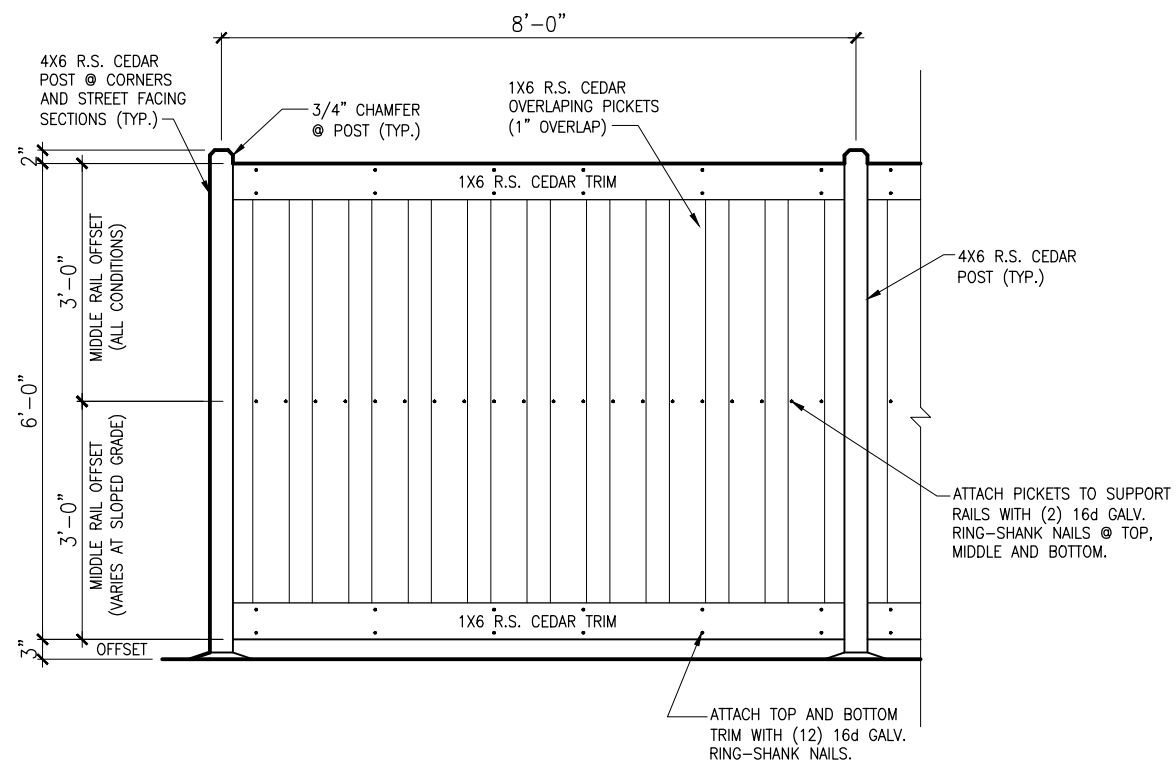

2 FENCE TYPE A - EXTERIOR SIDE
SCALE: 1/2"=1'-0"

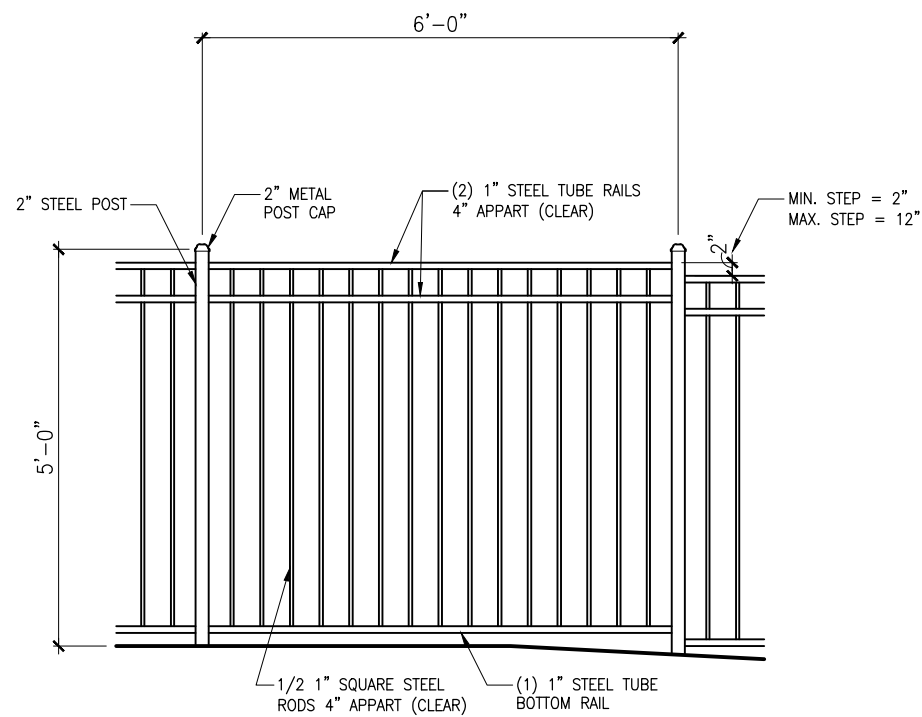

3 FENCE TYPE B
SCALE: 1/2"=1'-0"

CENTURY FARM - ONLY
Cedar Fence Finish
Woodscapes Flat - Flagstone Gray #815-T54 (SW3023)

CEDAR FENCE FINISH:

KWAL 8609 SEMI-TRANSPARENT STAIN
UP TO 2 COATS TO ACHIEVE UNIFORM COVERAGE

METAL FENCE FINISH:

SEMI-GLOSS BLACK RUSTOLEUM ENAMEL PAINT
60% GLOSS BLACK POWDER COATING

4 FENCE FINISHES